

Chapter4

Recurrent Evolving Systems, Reinforcement Learning and Evolving Automata

Prof. Nik Kasabov

nkasabov@aut.ac.nz

<http://www.kedri.info>

Overview

- Recurrent evolving Connectionist Systems
- Evolving Connectionist Systems and Evolving Automata
- Reinforcement Learning in ECOS

Recurrent Evolving Connectionist Systems

- These systems have feedback connections from hidden or output layers of neurons back to the inputs or to the hidden layer nodes.
- Recurrent structures capture temporal dependencies (not always known in advance) between the presented data examples from the data stream.

Recurrent EFuNN Structures

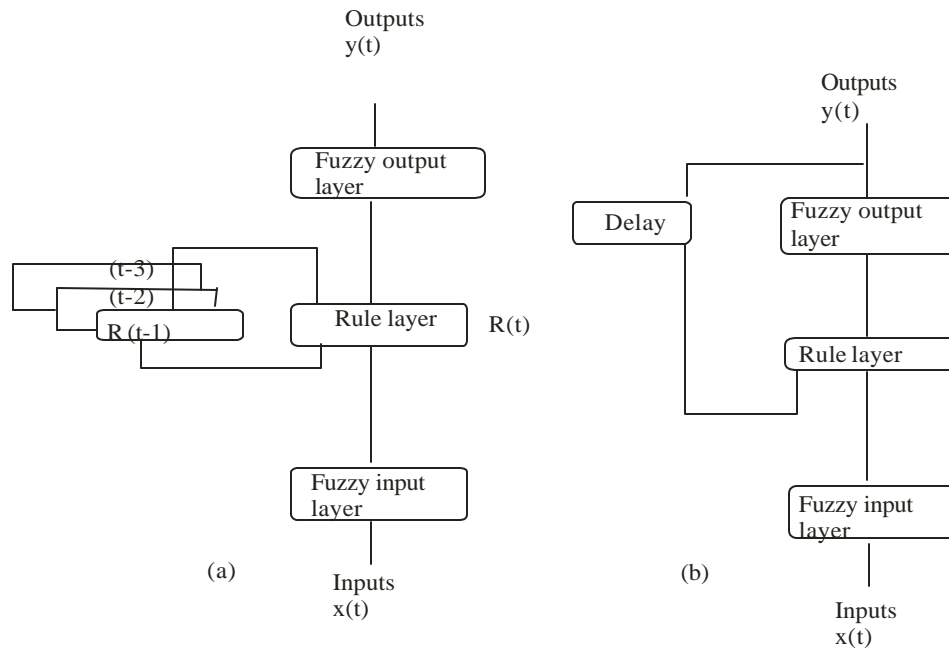

Two types of recurrent EFuNN structures: a) recurrent connections from the rule layer; b) recurrent connections from the output layer (Fig 4.1)

Recurrent EFuNN for Fuzzy Automata

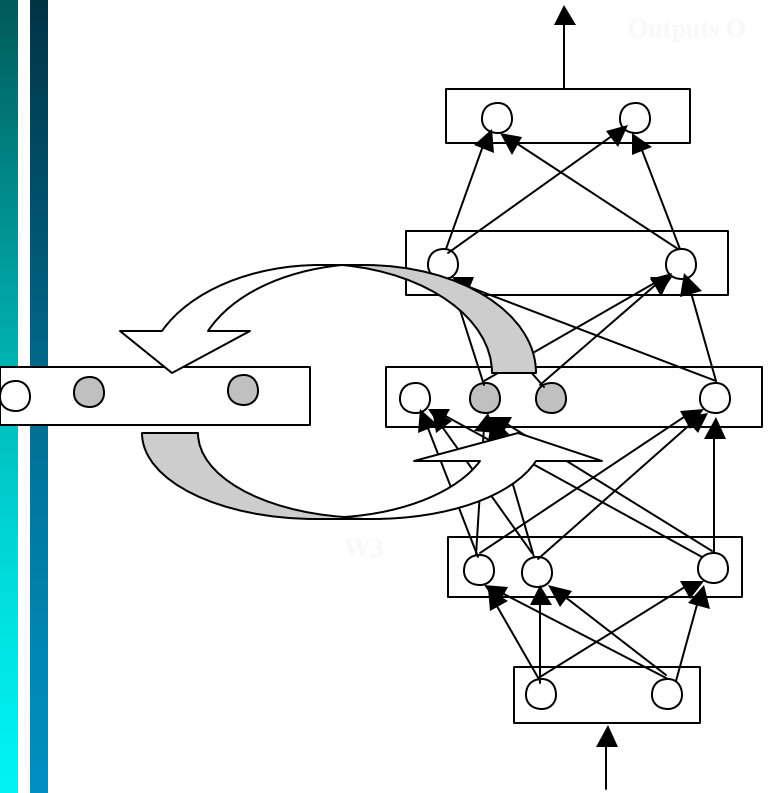

Outputs
Fuzzy Outputs
States $S(t)$
Fuzzy Input Layer

Recurrent EFuNN for the realisation of an evolving fuzzy automation.

The transitions between states are captured in the short-term memory layer and feedback connections. (Fig 4.4)

ECOS and Evolving Automata

- Finite Automata and Recurrent Networks
 - » Deterministic finite state automaton
 - » Recurrent connectionist architectures, having the feature to capture time dependencies, are suitable techniques to implement finite automata
- Evolving Automata
 - » In an evolving automaton, the number of states in the set S is not defined *a priori*; rather it increases and decreases in a dynamic way, depending on the incoming data
 - » A recurrent EFuNN can realize an evolving fuzzy automaton

Reinforcement Learning in ECOS

- Based on similar principles as supervised learning, but there is no exact desired output and no calculated exact output error.
- There are several cases in an evolving reinforcement learning procedure:
 - » There is a rule node activated (by the current input vector \mathbf{x}) above the pre-set threshold, and the fuzzy output node activated the highest is the same as the received fuzzy hint.
 - » Otherwise, there will be a new rule node created and new output neuron (or new module) created to accommodate this example.
- This type of a recurrent EFuNN can be used in mobile robots that learn and evolve as they operate

Recurrent EFuNN

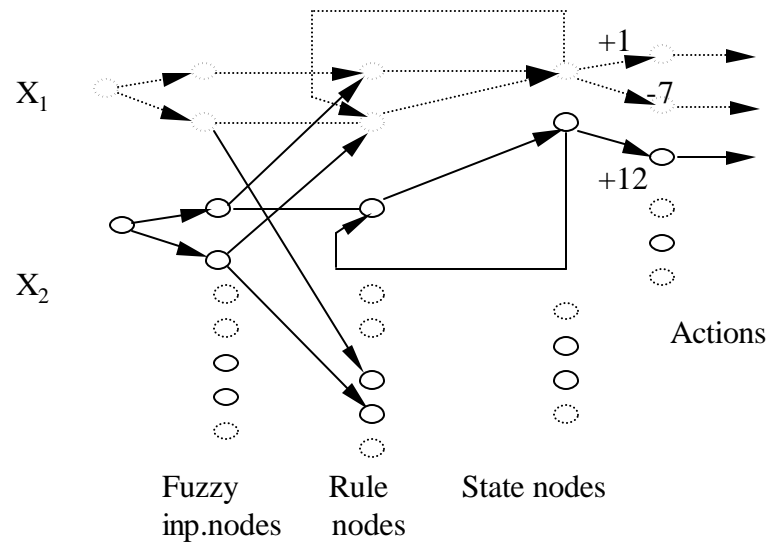

An exemplar recurrent EFuNN for reinforcement learning (Fig 4.5)

Summary

- Methods outlined indicate potential of ECOS for
 - » Learning in a reinforcement mode
 - » Learning temporal dependencies
 - » Realisation of evolving finite automata

Further Reading

- Recurrent structures of NN (Elman, 1990; Arbib, 1995, 2002).
- Finite automata and their realization in connectionist architectures (Arbib, 1987; Omlin and Giles, 1994).
- Introduction to the theory of automata (Zamir, 1983; Hopkin and Moss, 1976).
- Symbolic knowledge representation in recurrent neural networks (Omlin and Giles, 1994)
- Reinforcement learning (Sutton and Barto, 1998).